

Unique Solutions For Unique Situations



Installation Manual

Operation Manual

LP SERIES Self-Priming Centrifugal Pumps

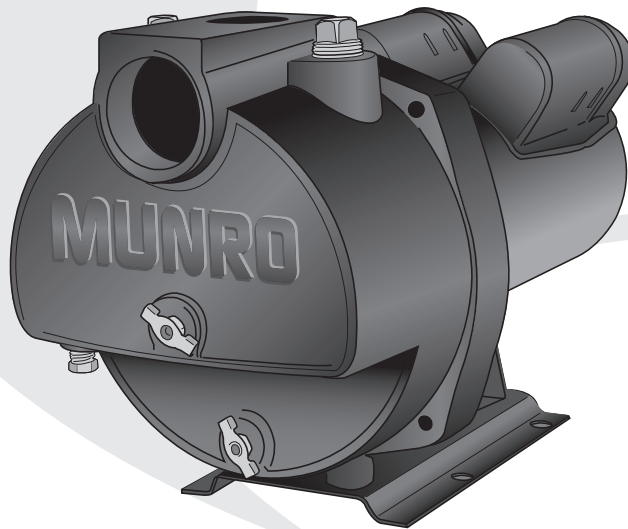

READ ALL INSTRUCTIONS CAREFULLY

Read these installation instructions in detail before installing your pump. As pump performance depends largely on installation be sure to check the following:

1. Be certain the motor is connected for the correct line voltage being

used (*check motor nameplate*).

2. Be certain the pump is completely primed before starting or damage may occur to the seal.

MUNRO LP SERIES CENTRIFUGAL IRRIGATION PUMP

GENERAL SAFETY INFORMATION

1. Follow all local electrical and safety codes, as well as the National Electrical Code (NEC) and the Occupational Safety and Health Act (OSHA)
2. Replace damaged or worn wiring cord immediately.
3. Do not kink power cable or allow the cable to come in contact with oil, grease, hot surfaces, or chemicals.
4. Protect the power cable from coming in contact with sharp objects.
5. Be careful when touching the exterior of an operating motor - it may be hot enough to be painful or cause injury.
6. Make certain the power source conforms to the requirements of your equipment.
7. **Always disconnect power source before performing any work on or near the motor or its connected load.** If the power disconnect point is out-of-sight, lock it in the open position and tag it to prevent unexpected application of power. Failure to do so could result in fatal electrical shock.
8. Do not handle the pump with wet hands or when standing in water as fatal electrical shock could occur. Disconnect main power before handling unit for **ANY REASON!**
9. Unit must be securely and adequately electrically grounded. This can be



accomplished by wiring the unit to a ground metal-clad raceway system or by using a separate ground wire connected to the bare metal of the motor frame or other suitable means.

LOCATION OF PUMP

1. Pump can be located at the water source or can be offset some distance away. For best performance, it should be located as close to the water source as is practical.
2. Location can be in the basement, a pit below ground, or in a pump house above ground.

TABLE 2 - SPECIFICATIONS

HP	Type	Volts/Amps	Hz	RPM	Motor Voltage (Factory) Connected	Service Factor Motor Amps						Max Liquid Temp	Max▲ Suction Lift
						Single Phase			Three Phase				
						115V	208V	230V	208V	230V	460V		
3/4	Single Ph	115/208-230 230	60	3450	230V	10	5	5	—	—	—	180°F	15 Ft.
1						15.6	8.8	7.8					
1-1/2						13.4	7.4	6.7					
2						—	—	12.9					
3						—	—	19.6					
3/4	Three Ph	208-230/460	60	3450	230V	—	—	—	†	1.6	†	180°F	15 Ft.
1						—	—	—	†	2.5	†		
1-1/2						—	—	—	†	2.5	†		
2						—	—	—	†	4.1	†		
3						—	—	—	†	7.0	†		

▲ Suction lift varies, depending upon elevation (*altitude*) and water temperatures. † For amperage ratings consult motor nameplate.

TABLE 1 - PUMP PERFORMANCE

Model Number	Phase	HP	Suction Lift Feet	Capacity - U.S. Gallons Per Minute Discharge Pressure (PSI)								Shut Off Pressure PSI	Suction Pipe Tap	Discharge Pipe Tap
				10	15	20	25	30	35	40	45			
MULP075B	1	3/4	5	56	48	42	37	29	21	-	-	41	2"	1-1/2"
MULP100B	1	1	5	58	53	48	43	38	32	23	11	48	2"	1-1/2"
MULP150B	1	1-1/2	5	78	77	71	70	62	53	43	30	47	2"	1-1/2"
MULP200B	1	2	5	86	84	81	77	71	62	52	40	50	2"	1-1/2"
MULP300B	1	3	5	102	101	101	97	91	85	76	68	63	2"	1-1/2"
MULP075B3	3	3/4	5	56	48	42	37	29	21	-	-	41	2"	1-1/2"
MULP100B3	3	1	5	58	53	48	43	38	32	23	11	48	2"	1-1/2"
MULP150B3	3	1-1/2	5	78	77	71	70	62	53	43	30	47	2"	1-1/2"
MULP200B3	3	2	5	86	84	81	77	71	62	52	40	50	2"	1-1/2"
MULP300B3	3	3	5	102	101	101	97	91	85	76	68	63	2"	1-1/2"

MOTOR VOLTAGE — Single Phase: 3/4 through 1-1/2HP - 115V/208V-230V - 60Hz • 2HP & 3HP - 230V - 60Hz

Three Phase: 3/4 through 3HP - 208V-230V/460V - 60Hz

MAXIMUM CASE PRESSURE — 100 PSI

MUNRO LP SERIES DIMENSIONS

Dimensions are for estimating purposes only.

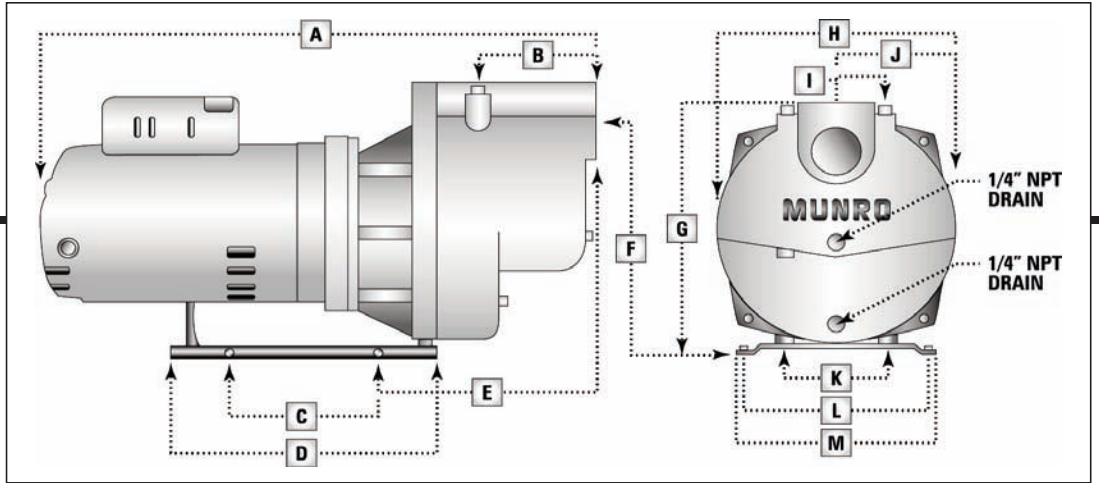

HP	DISCHARGE	SUCTION	A	B	C	D	E	F	G	H	I	J	K	L	M
3/4	1 1/2"	2"	17 3/4"	3 5/8"	4 1/4"	8 1/2"	7 1/2"	9 1/2"	10 7/8"	9 1/2"	2 3/8"	4 3/4"	2 5/8"	5 1/4"	6"
1	1 1/2"	2"	17 3/4"	3 5/8"	4 1/4"	8 1/2"	7 1/2"	9 1/2"	10 7/8"	9 1/2"	2 3/8"	4 3/4"	2 5/8"	5 1/4"	6"
1 1/2	1 1/2"	2"	17 3/4"	3 5/8"	4 1/4"	8 1/2"	7 1/2"	9 1/2"	10 7/8"	9 1/2"	2 3/8"	4 3/4"	2 5/8"	5 1/4"	6"
2	1 1/2"	2"	18"	3 5/8"	4 1/4"	8 1/2"	7 1/2"	9 1/2"	10 7/8"	9 1/2"	2 3/8"	4 3/4"	2 5/8"	5 1/4"	6"
3	1 1/2"	2"	18"	3 5/8"	4 1/4"	8 1/2"	7 1/2"	9 1/2"	10 7/8"	9 1/2"	2 3/8"	4 3/4"	2 5/8"	5 1/4"	6"

ELECTRICAL CONNECTIONS

WIRING CONNECTIONS

- The unit is not waterproof and is not intended to be used in showers, saunas, or other potentially wet locations. The motor is designed to be used in a clean dry location with access to an adequate supply of dry cool air. Ambient temperature around the motor should not exceed 104°F or 40°C. For outdoor installations, motor is designed for rain — up to a 15° angle of impact. If conditions require increased protection, the pump must be protected by a cover that does not block air flow to, and around the motor. This unit is not weatherproof nor is it able to be submersed in water, or any other liquid.
- Single phase motors, 3/4 to 1-1/2 HP, are tri-voltage (115/208-230) and can be connected for 115V or 230V service. The 2 & 3 HP single phase motors are 208-230V only. Single phase motors are factory connected for 230V at the motor.
- All three phase motors are 208-230/460 volts and are factory connected at the motor for 230 volts.
- If the motor wiring must be changed to conform to your specific voltage requirements then the motor should be rewired. For proper electrical connections, refer to the connection diagram located on the nameplate of the motor or one of the following diagrams. Make sure connections are correct for the voltage being supplied to the motor.

WARNING: Always disconnect power source before performing any work on or near the motor or its power source. Failure to do so could result in personal injury or fatal electrical shock.

DIAGRAM B-1
WIRING DIAGRAM FOR SINGLE PHASE 2 & 3 HP
 CHECK VOLTAGE OF POWER SOURCE BEFORE CONNECTING.
 DO NOT CONNECT ANY GROUND WIRE TO THESE LEADS.

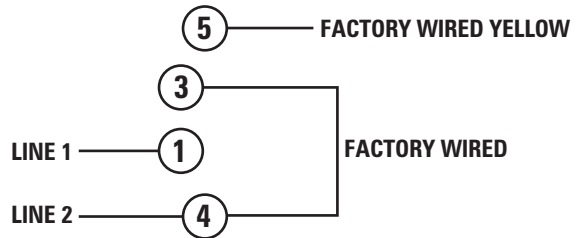

DIAGRAM B
WIRING DIAGRAM FOR SINGLE PHASE 3/4 to 1-1/2 HP
 CHECK VOLTAGE OF POWER SOURCE BEFORE CONNECTING.
 DO NOT CONNECT ANY GROUND WIRE TO THESE LEADS.

ROTATION CW - OPE

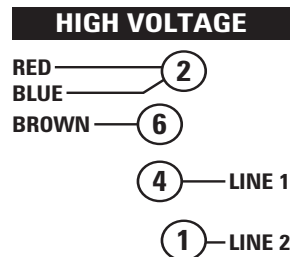
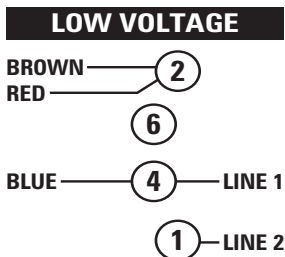
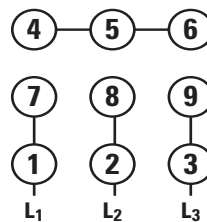
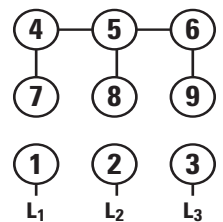

DIAGRAM B-2
WIRING DIAGRAM FOR THREE PHASE
 CHECK VOLTAGE OF POWER SOURCE BEFORE CONNECTING.
 DO NOT CONNECT ANY GROUND WIRE TO THESE LEADS.

LOW VOLTAGE
230V



HIGH VOLTAGE
460V



NOTE: To reverse rotation, interchange any two incoming line (power) leads.

MOTOR PROTECTION

1. All single-phase motors through 2 HP, and some 3 HP, have built-in thermal overload protection. All single-phase motors without thermal protection, must be wired externally. The overload protects the motor against burnout from overload of low voltage, high voltage and other causes. The device is automatic and resets itself once the temperature has dropped to a safe point. Frequent tripping of the device indicates trouble in the motor or power lines and immediate attention is needed. The device should never be tampered with unless the trouble is located and corrected.

WARNING: Never examine, make wiring changes, or touch the motor before disconnecting the main electrical supply switch. The thermal device may have opened the electrical circuit.

2. Three-phase motors do not have built-in thermal protection. It is recommended that a properly sized magnetic or manual starter (both with properly sized heaters) be used with all three-phase motors. Install starters following instructions of the starter manufacturer. See Diagram C for magnetic starter wiring program.
3. All motors (single and three phase) should be equipped with a correctly fused disconnect switch to provide protection. Consult local or national electric codes for proper fuse protection based on the motor data, located on the motor nameplate.
4. Undersize wiring can cause motor failure (low voltage), frequent cut-out of motor overload protector, television interference and even fire. Make certain wiring is adequately sized (See Diagram D), well insulated, and connected to a separate circuit outside the house in case of fire.

OPERATION

1. When installation has been completed, remove the priming plug from the pump housing and fill the pump body and suction pipe completely with water. No additional water will be needed for subsequent start-ups unless the pump body is drained.
2. After the pump is turned on, it will require 2-5 minutes before all the air is evacuated from the suction line and water begins to flow. If there is not water after 10 minutes, turn the pump off and verify the following:
 - a) Any air leaks on the suction line are eliminated.
 - b) Total suction lift is not greater than 25 feet at sea level.
 - c) Any restrictions in the discharge line such as a closed valve, must be remedied.

NOTE: Unit must be full of liquid before operating. Never run dry or against a closed discharge. Dry running or running unit against a closed discharge will cause damage to the shaft seal. Do not pump dirty water or abrasive liquids, or the same damage may occur as if running dry.

MOTOR ROTATION

1. Single phase models are one rotation only (counterclockwise when facing the pump suction tapping) and cannot be reversed.

2. Proper rotation of pump impeller is critical for three-phase pumps. Pump motor should turn counterclockwise (CCW) when facing pump suction tapping. Momentarily "bump" (apply power for less than a second) the motor to check for proper rotation. To change rotation on three-phase units, interchange any two incoming line (power) leads.

MAINTENANCE

Lubrication

1. The pumps and motors require no lubrication. The ball bearings of the motor have been greased and sealed at the factory. Under normal operating conditions they should require no further greasing.

Freezing

1. Drain the entire system if there is danger of freezing. Two drain valves are provided in the pump case for this purpose.

ROTARY SEAL ASSEMBLY REPLACEMENT

CAUTION: Make certain the power supply is disconnected before attempting to service the unit! The rotary seal assembly must be handled carefully to avoid damaging the precision lapped faces of the sealing components.

1. Disengage pump body (Ref. No. 8) from motor and mounting ring (Ref. No. 7) by removing bolts.
- (See parts list for reference numbers)
2. Remove diffuser bolts and remove diffuser (Ref. No. 6).
3. Unthread impeller (Ref. No. 5) from motor shaft.

NOTE: To remove the impeller use a 9/16" open end wrench to hold the motor shaft. The shaft flat area is located in the middle of the mounting ring.

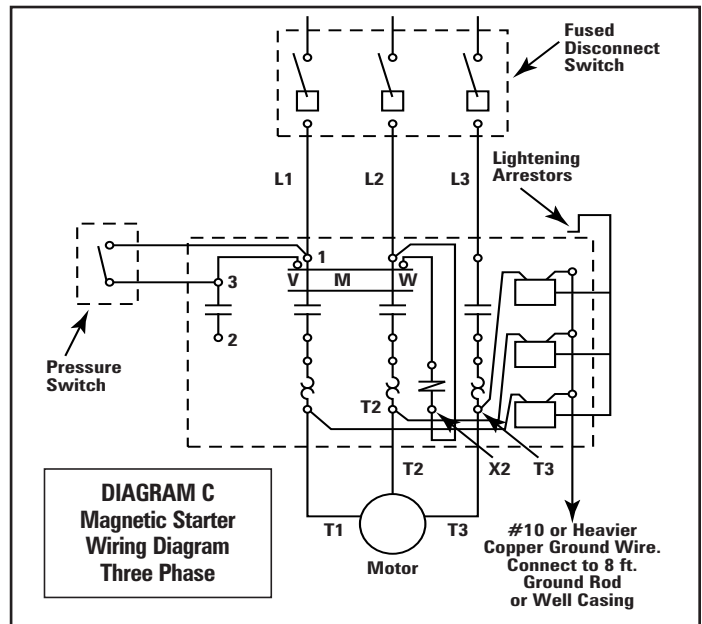

DIAGRAM C
Magnetic Starter
Wiring Diagram
Three Phase

WIRING SIZE CHART - DIAGRAM E

Distance From Motor Fuse Box Meter or Electrical Outlet	Minimum Copper Wire Size Chart (Gauge)																	
	Single Phase Motors									Three Phase Motors								
	3/4 HP		1 HP		1-1/2 HP		2 HP	3 HP	3/4 HP		1 HP		1-1/2 HP		2 HP	3 HP		
	115 Volt	230 Volt	115 Volt	230 Volt	115 Volt	230 Volt	230 Volt	230 Volt	230 Volt	460 Volt	230 Volt	460 Volt	230 Volt	460 Volt	230 Volt	460 Volt	230 Volt	460 Volt
0-50 Feet	12	14	10	14	10	12	12	10	14	14	14	14	14	14	14	14	14	14
50-100 Feet	12	14	10	14	8	12	12	10	14	14	14	14	14	14	14	14	14	14
100-150 Feet	10	14	10	12	6	12	12	10	14	14	14	14	14	14	14	14	14	14
150-200 Feet	10	12	8	12	•	10	10	10	14	14	14	14	12	14	12	14	12	14
200-300 Feet	8	12	6	10	•	10	10	8	14	14	12	14	12	14	10	12	10	12
Full Size (Amps)	20	15	30	15	30	20	20	30	15	15	15	15	15	15	15	15	15	15

• NOT ECONOMICAL TO RUN IN 115VOLT, USE 230 VOLT

- The rotary Seal (Ref. No. 4) will come loose at this time. Use a screwdriver (or similar instrument) to pry the ceramic seal and the rubber gasket from the recess of the mounting bracket.

CAUTION: Be careful not to damage the motor shaft or recess surface.

NOTE: Because damage to the shaft seal is most likely to occur in disassembly, a new seal will be necessary.

- Clean the recess and motor shaft thoroughly.
- Install the new rotary seal assembly:
 - Insert the ceramic seal and the rubber gasket into the recess.

NOTE: To help facilitate installation, apply a light coating of oil to the outside diameter of the rubber gasket. Make certain the ceramic seal is kept clean and free of dirt and/or oil.

- Slip the remaining parts of the rotary seal assembly onto the motor shaft.
- Replace the impeller and diffuser removed in Steps 2 and 3.
 - Insert rubber diffuser into pump body cavity.

- Reassemble the pump body to the motor and mounting bracket.

MOTOR REPLACEMENT

- NEMA J motors can be replaced in the field with any standard NEMA J jet pump motor by referring to the following instructions and the attached parts list.
- Follow Steps 1 through 4 as outlined under rotary seal replacement to remove the pump body, diffuser, impeller and rotary seal.
- Remove bolts that connect the motor (Ref. No. 1) and pull motor away.
- Replace motor with standard NEMA J jet pump motor by positioning motor against the mounting frame and assembling with four 3/8" x 3/4" cap screws. The mounting base is connected at the bottom of the mounting frame with two 3/8" x 1/2" cap screws.
- Follow Steps 5, 6, 7 and 8 of Rotary Seal Assembly to reassemble the remainder of the pump.

NOTE: Because damage to the shaft seal is most likely to occur in disassembly, a new seal will be necessary.

LP SERIES — SELF-PRIMER PUMP REPAIR PARTS

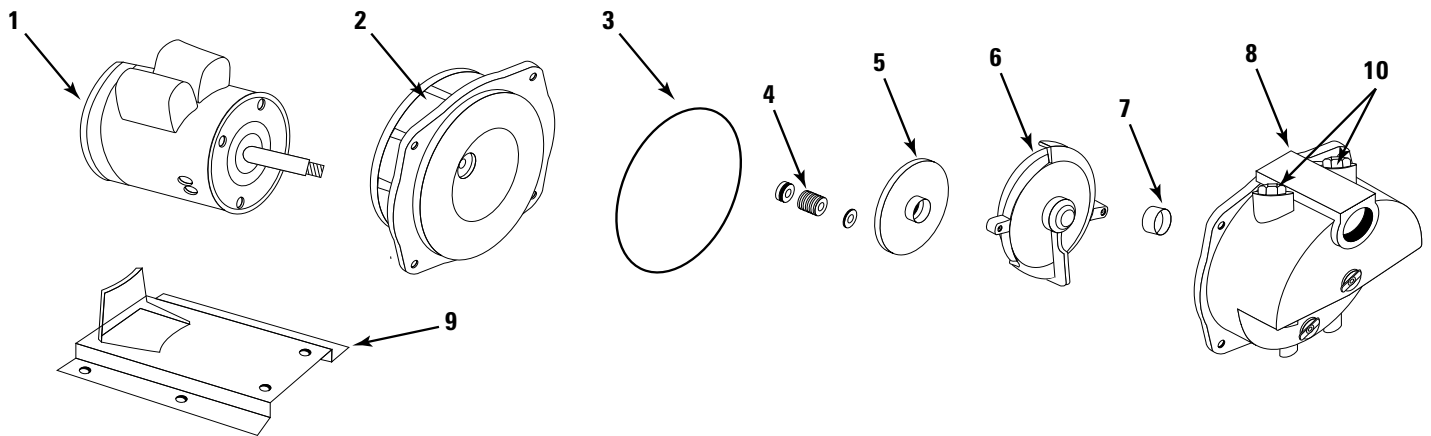

ITEM	SINGLE PHASE DESCRIPTION	HORSEPOWER MODEL NO, PART NO.	3/4	1	1-1/2	2	3
			MULP075B	MULP100B	MULP150B	MULP200B	MULP300B
1	MOTOR, NEMA J - 1 PHASE ▲ MOTOR ACCESS COVER SCREW, ACCESS COVER		MLP07B1	MLP10B1	MLP15B1	MLP20B1	MLP30B1
▲	SLINGER, WASHER	MLP5030	1	1	1	1	1
2	MOUNTING RING	MLP3010	1	1	1	1	1
▲	HEX HD. CAP SCREWS 3/8 x 3/4"	MLP9010	1	1	1	1	1
3	RING, SQUARE CUT	MLP5010	4	4	4	4	4
4	SEAL, ROTARY W/SPRING	MLP6200	1	1	1	1	1
5	IMPELLER, BRASS "B" MODELS		MLP407B	MLP410B	MLP415B	MLP420B	MLP430B
6	DIFFUSER	MLP2010	1	1	1	1	MLP2011
▲	HEX HD. CAP SCREWS 1/4 x 1"	MLP9020	2	2	2	2	2
7	RUBBER DIFFUSER	MLP5020	1	1	1	1	1
8	PUMP BODY	MLP1010	1	1	1	1	1
▲	HEX HD. CAP SCREWS 7/16 x 1"	MLP9030	4	4	4	4	4
9	BASE - 48 Y-FRAME MOTOR	MLP801048	1	1	1	—	—
▲	BASE - 56 J-FRAME MOTOR	MLP801056	—	—	—	1	1
▲	HEX HD. CAP SCREWS 3/8 x 1/2"	MLP9040	2	2	2	2	1
▲	PET COCK	•					
10	3/4" PRIMING PLUG	•					

(•) Standard Hardware Item

(▲) Not Shown

TROUBLESHOOTING CHART

SYMPTOM	POSSIBLE CAUSE(S)	CORRECTIVE ACTION
Little or no discharge	<ol style="list-style-type: none"> 1. Casing not initially filled with water to prime pump 2. Total head too high 3. Suction lift too high, or too long 4. Impeller plugged 5. Hole or air leak in suction line 6. Foot valve too small 7. Impeller damaged 8. Foot valve or suction line not submerged deep enough in water 9. Insufficient inlet pressure or suction head 10. Suction piping too small 11. Motor wired incorrectly 12. Casing gasket leaking 13. Suction or discharge line valves closed 	<ol style="list-style-type: none"> 1. Fill pump casing 2. Shorten suction lift and/or change head 3. Lower suction lift, install foot valve and prime, or shorten length of suction line. 4. Clean impeller 5. Repair or replace suction line; do not use Teflon tape; use pipe sealing compound 6. Match foot valve to piping or install one size larger foot valve 7. Replace impeller 8. Submerge lower in water 9. Increase inlet pressure by adding more water to tank or increasing back pressure 10. Increase to pump inlet size or one size larger 11. Check wiring diagram for correct wiring 12. Replace gasket 13. Open suction and/or discharge lines
Pump will not deliver water or develop pressure	<ol style="list-style-type: none"> 1. No priming water in casing 2. Mechanical seal is leaking 3. Leak in suction line 4. Discharge line is closed and priming air has nowhere to go 5. Suction line (or valve) is closed 6. Poor pump performance 7. Foot valve is leaking 8. Suction screen is clogged 	<ol style="list-style-type: none"> 1. Fill pump casing 2. Replace seal (<i>See Rotary Seal Replacement</i>) 3. Repair or replace 4. Open discharge line 5. Open suction line or valve 6. Replace worn parts 7. Replace foot valve 8. Clean or replace screen
Loss of suction	<ol style="list-style-type: none"> 1. Air leak in suction line 2. Suction lift is too high 3. Insufficient inlet pressure or suction head 4. Clogged foot valve or strainer 	<ol style="list-style-type: none"> 1. Repair or replace suction line 2. Lower suction lift, install foot valve and prime 3. Increase inlet pressure by adding more water to tank or increasing back pressure 4. Unclog
Pump vibrates and/or makes excessive noise	<ol style="list-style-type: none"> 1. Mounting plate or foundation not rigid enough 2. Foreign material in pump 3. Impeller damaged 4. Worn motor bearings 5. Suction lift too high 	<ol style="list-style-type: none"> 1. Reinforce 2. Disassemble pump and clean 3. Replace impeller 4. Replace bearings 5. Lower suction lift, install foot valve and prime
Pump will not start or run	<ol style="list-style-type: none"> 1. Improper wiring 2. Blown fuse or open circuit breaker 3. Loose or broken wiring 4. Stone or foreign object lodged in impeller 5. Motor shorted out 6. Thermal overload has opened circuit 	<ol style="list-style-type: none"> 1. Check wiring diagram on motor 2. Replace fuse or close circuit breaker 3. Tighten connections, replace broken wiring 4. Disassemble pump and remove foreign object 5. Replace 6. Allow unit to cool, restart after reason for overload has been determined
Pump leaks at shaft	<ol style="list-style-type: none"> 1. Worn mechanical seal 	<ol style="list-style-type: none"> 1. Replace (<i>see Rotary Seal Replacement</i>)

Unique Solutions For Unique Situations



Installation Manual

Operation Manual

*For more information or details
on this or any other product, contact your
Munro Pump Sales Representative today!*

GRAND JUNCTION, COLORADO 81501

800-942-4270

FAX: 970-263-2277

OR VISIT US ON THE WORLD WIDE WEB:

