

PUMP CURVE

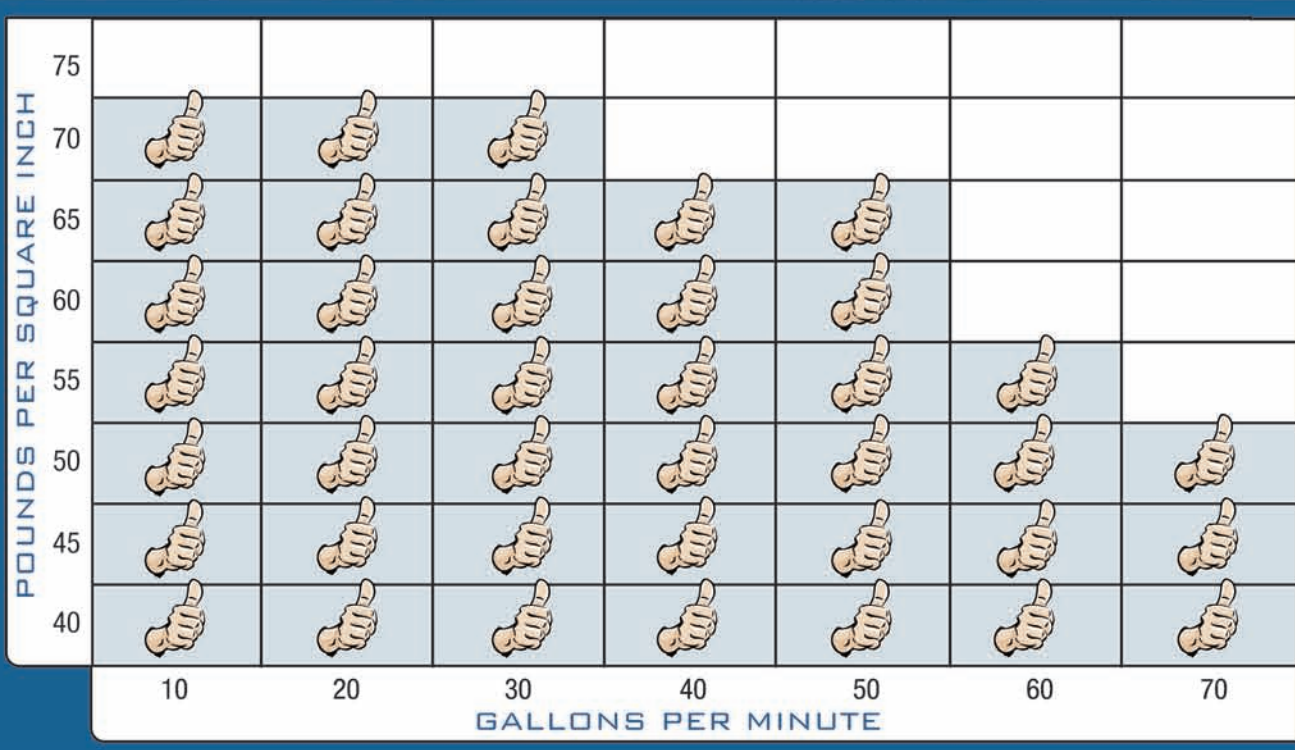

SIMPLICITY 70VFD

BY MUNRO SYSTEMS

The Smart Drive Package At Fixed Speed Prices



THE SIMPLEST PACKAGE ON EARTH

One Self-Contained Unit...Water and electrical power are the only requirements for a smooth operating system.

Simpler Maintenance
Lower operating speeds result in longer life for bearings and motors

Simpler For Your System
A soft start and controlled ramp-up speed eliminates water hammering and reduces maintenance

Simpler Controls
No throttling valves or dampers means fewer controls for simpler operation



FOR MORE INFORMATION ABOUT OTHER INNOVATIVE PRODUCTS BY MUNRO, CALL FOR THE DISTRIBUTOR NEAREST YOU
 PHONE: 877-372-9005 • FAX: 970-241-1368
 E-MAIL: MSY@munrocompanies.com
 WEBSITE: www.munrosystems.com
STANDALONE BROCHURE / REVISED / © 2008 MUNRO SYSTEMS INC. ALL RIGHTS RESERVED

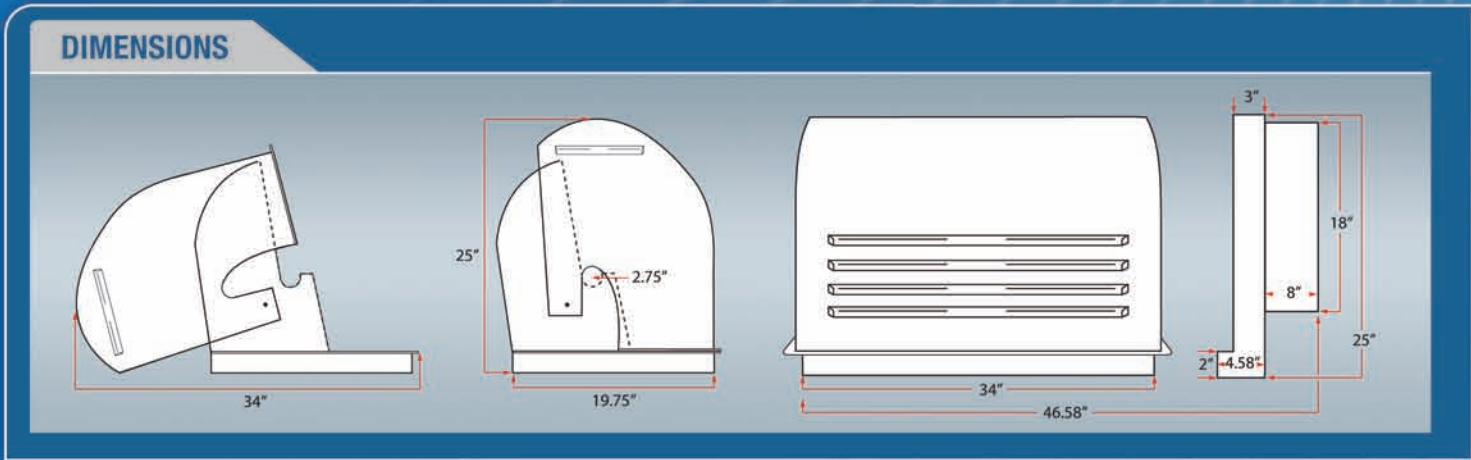
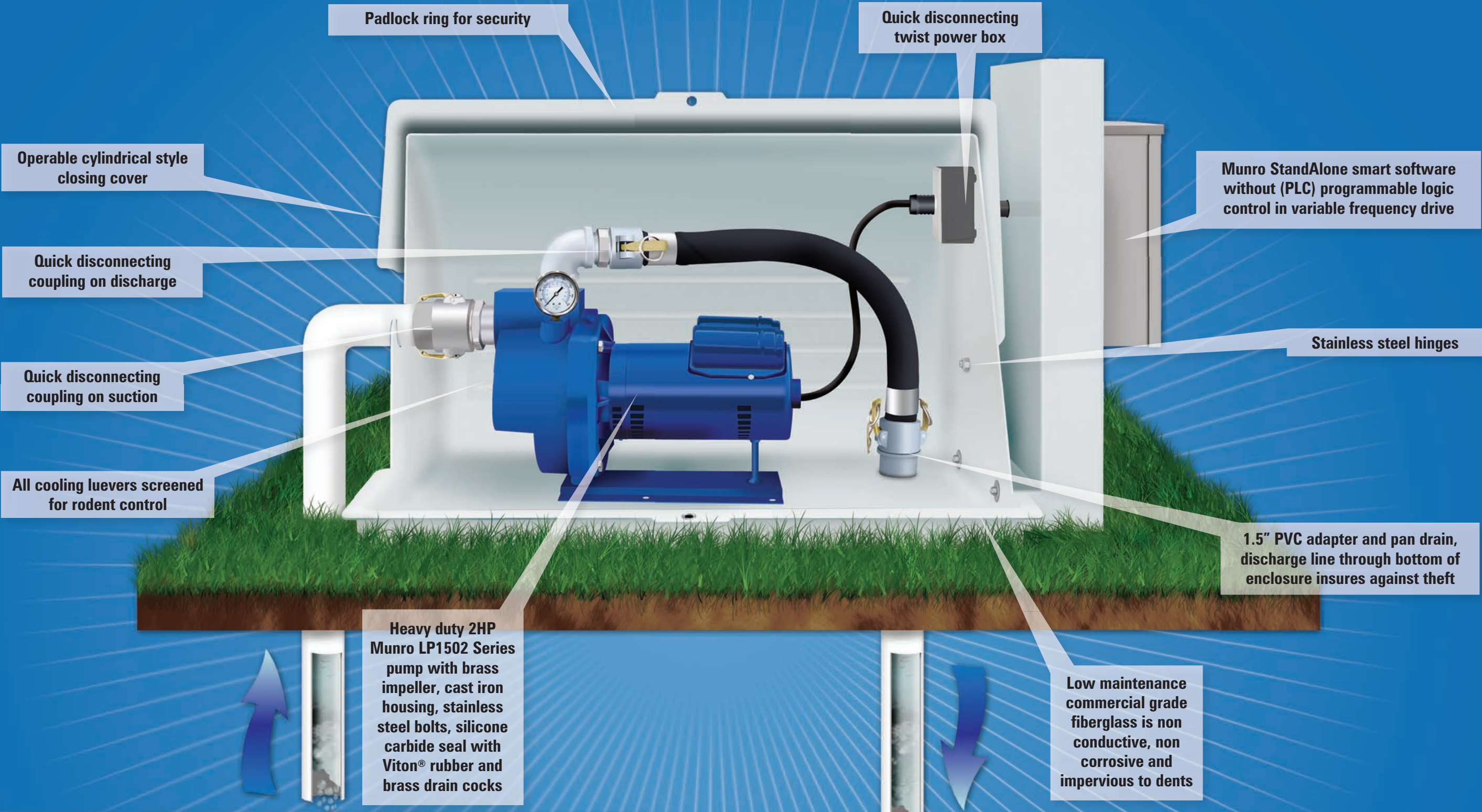

MODEL SS70VFD21230

PUMP	MINIMUM GPM	MAXIMUM GPM	MINIMUM PSI	MAXIMUM PSI
LP1502B	8	70	50	75

MAXIMUM CASE PRESSURE: 150 PSI